

APPENDIX IV
WASTE ANALYSIS PLAN

Evoqua Water Technologies
2523 Mutahar Street
Parker, Arizona 85344
928-669-5758

March 2016
Revision 2

TABLE OF CONTENTS

<u>Section</u>	<u>Page No.</u>
1.0 INTRODUCTION.....	1
2.0 INFORMATION SUPPLIED BY HAZARDOUS WASTE GENERATORS	2
3.0 PROCEDURES USED TO INSPECT SPENT CARBON RECEIVED	4
4.0 CONFIRMATION OF COMPOSITION OF SPENT CARBON RECEIVED.....	5
4.1 CONTAINERIZED SPENT CARBON	5
4.2 BULK SPENT CARBON	5
4.3 ON-SITE SCREENING	5
4.4 RATIONALE FOR ANALYSES SELECTED FOR ON-SITE SCREENING.....	6
4.5 ANALYSES PERFORMED FOR PERMIT COMPLIANCE	6
5.0 PROCEDURES USED TO OBTAIN A REPRESENTATIVE SAMPLE OF SPENT CARBON.....	11
5.1 BULK LOADS.....	11
5.2 CONTAINERS	11
5.3 CARBON FEED.....	12
5.4 MAINTAINING AND DECONTAMINATING SAMPLING EQUIPMENT	12
5.5 SAMPLING QA/QC PROCEDURES	12
6.0 METHODS TO ENSURE COMPATIBILITY WITH HANDLING METHODS.....	13
7.0 METHODS TO ENSURE WASTE ANALYSIS PLAN IS KEPT UP-TO-DATE	14
8.0 LAND DISPOSAL RESTRICTION NOTIFICATION FORMS	15
9.0 SPECIAL PROCEDURAL REQUIREMENTS	16
9.1 SUBPART BB.....	16
9.2 SUBPART CC	16
9.3 WASTES GENERATED ON-SITE.....	16

LIST OF TABLES

<u>Table No.</u>		<u>Page</u>
4-1	SUMMARY OF PRE-ACCEPTANCE ANALYTICAL PARAMETERS, RATIONALE, AND TEST METHODS	7
4-2	SUMMARY OF ON-SITE SCREENING ANALYTICAL PARAMETERS, RATIONALE, AND TEST METHODS	8
4-3	SUMMARY OF PERMIT COMPLIANCE ANALYTICAL PARAMETERS, RATIONALE, AND TEST METHODS	9

LIST OF FIGURES

<u>Figure No.</u>		<u>Follows Page</u>
4-1	SAMPLE LOCATIONS.....	7

LIST OF APPENDICES

Appendix

- A SPENT CARBON PROFILE FORM
- B INCOMING SPENT CARBON WASTE TALLY SHEET
- C EVOQUA WATER TECHNOLOGIES ON-SITE SCREENING PROCEDURES

Note that the appendices are included with the WAP for informational purposes, and represent examples of the types of information contained in these documents. The actual documents may be modified from time to time as deemed necessary by the facility, without changing the WAP.

1.0 INTRODUCTION

This Waste Analysis Plan has been prepared for the Evoqua Water Technologies (EWT) carbon reactivation facility located in Parker, Arizona. It is intended to comply with the waste analysis requirements found in 40 CFR Part 264.13 and 265.13. A description of the facility can be found in Section D of the facility's RCRA Part B permit application. This Waste Analysis Plan applies only to spent carbon that is classified as hazardous waste in accordance with 40 CFR Part 261.

The procedures and information that make up this document establish EWT's policy for the acceptance of spent carbon classified as hazardous waste and the analysis of spent carbon. The forms contained in this Waste Analysis Plan are offered to establish the general information to be documented. The format and wording of these forms may be changed from time to time without modifying the Waste Analysis Plan. EWT will provide copies of these forms to EPA as they are revised.

All records are retained in accordance with the recordkeeping requirements of 40 CFR 264.73. EWT's records retention requirements are summarized in Appendix XXI.

2.0 INFORMATION SUPPLIED BY HAZARDOUS WASTE GENERATORS

Spent carbon processed at the EWT facility will be received only after it is pre-approved for processing by EWT as described below.

The prospective generator (originator) of a source of spent carbon will begin the approval process by making application to EWT using a Spent Carbon Profile Form (SCPF). The generator will complete the SCPF in accordance with the guidance supplied with each form. The information supplied by the generator must be from analysis of a sample which is representative of the spent carbon being profiled. An example of a SCPF can be found in Appendix A.

Section 3 of the SCPF provides space for the generator to provide a specific description of the process generating the spent carbon including constituents being treated. A copy of the analytical data must be included with the SCPF.

EWT will perform a completeness review on each SCPF. Should any deficiencies be found, EWT will work with the generator to ensure the SCPF is complete before proceeding with the pre-acceptance process.

In order to ensure proper storage and treatment of the spent carbon, at a minimum, the pre-acceptance parameters listed in Table 4-1 will be determined for all samples before final profile approval is given. Table 4-1 also lists the rationale for the analyses chosen as well as the analytical methods to be used. EWT will make a determination of what additional analyses, if any, will be performed based on the information supplied on the SCPF. As part of the profiling process, the generator must make a determination and indicate in the space provided on the SCPF that based on analytical data of the waste stream and/or their knowledge of the process producing the spent carbon whether the spent carbon is a hazardous waste as defined by 40 CFR Part 261. In all cases where a determination has been made that the spent carbon is a RCRA hazardous waste, the generator is required to provide analytical data for characterization.

Based on the information supplied on the SCPF and the results of the spent carbon analysis, the generator's spent carbon will either be approved or rejected for treatment at the Parker facility. The decision to approve or reject a generator's spent carbon will be made by EWT plant management. The generator will be advised of the determination. If the spent carbon is approved for treatment, the spent carbon will be assigned a spent carbon approval number.

The generator is required to submit a revised SCPF (including appropriate analytical data) whenever there is reason to believe that the nature of the spent carbon has changed (e.g., from process or operational modifications). At a minimum, each generator must submit an updated SCPF and current analytical data at least every two years. Analytical data submitted with the profile information must be no more than 6 months old.

In the case where EWT discovers that a shipment of spent carbon exhibits a significant discrepancy from the waste profile information, the generator will be required to re-

characterize the waste and may also be required to develop a new waste profile (including appropriate analytical data), before the shipment will be accepted for treatment.

3.0 PROCEDURES USED TO INSPECT SPENT CARBON RECEIVED

Upon arrival at the facility, each load will be inspected by a Material Handler or other qualified person to ensure the material is spent carbon and that the quantity of spent carbon agrees with the quantity stated on each manifest. For loads of containerized spent carbon, the drums or other containers will be counted to ensure that the quantity agrees with the manifest. Each container will be checked to ensure that a correctly completed hazardous waste label is present and that the label agrees with the contents stated on the manifest. After the quantity check, samples of the containerized spent carbon will be obtained as described in Section 5.

Bulk shipments will also be inspected. The manways or "domes" will be opened and the depth of the carbon will be visually inspected. The estimated quantity or volume in the truck will be compared with the quantity listed on the Hazardous Waste Manifest. After the quantity check, samples of the tank contents will be obtained as described in Section 5.

In the event further testing is required to make a decision or characterize the spent carbon, the facility may temporarily store the material pending analytical results.

An Incoming Spent Carbon Tally Sheet/On-Site Screening Report (see Appendix B) will be completed for each load by a Material Handler or other qualified person. This form will be filed and maintained as part of the facility's Operating Record.

4.0 CONFIRMATION OF COMPOSITION OF SPENT CARBON RECEIVED

As discussed in Section 2 of this document, the spent carbon generator is required to provide certain characterization and analytical data to SWT, prior to waste acceptance at the facility. Analytical data to be provided by the generator, including the rationale for the analysis, and the appropriate analytical methods, are described in Table 4-1.

The remainder of this section describes how facility personnel confirm that the materials received correspond to the pre-acceptance data supplied by the generator, and how facility personnel sample and analyze the incoming materials to confirm compliance with feed rate restrictions on the carbon reactivation unit. The locations within the facility and the carbon reactivation process where samples are collected are shown schematically in Figure 4-1.

4.1 CONTAINERIZED SPENT CARBON

Each container of spent carbon will be opened by a Material Handler or other qualified person, and the contents of the container will be visually inspected for foreign matter. The general appearance of the carbon will be observed. As described in the sampling procedure (see Section 5) representative samples will be obtained. A composite of the spent carbon samples from each load from each generator, or a single sample if only one container was received from the generator, will be subjected to the on-site screening tests listed in Table 4-2.

4.2 BULK SPENT CARBON

Each bulk load of spent carbon will be sampled by a Material Handler or other qualified person, as described in Section 5. Representative samples of the bulk load will be obtained as described in the sampling procedure in Section 5.0. The samples will be visually inspected for general appearance and the presence of foreign matter. A composite of the spent carbon samples will be subjected to the on-site screening tests listed in Table 4-2.

4.3 ON-SITE SCREENING

The composite samples obtained from each load from each generator's containerized spent carbon shipment and from bulk loads will be subjected to the on-site screening analyses listed in Table 4-2. EWT's procedures for on-site screening are provided in Appendix C to the WAP. The results of the analyses will be recorded on the Incoming Spent Carbon Waste Tally Sheet and On-Site Screening Report (see Appendix B) by trained personnel and reviewed by plant management. If the spent carbon is accepted, the spent carbon will be transferred into a designated storage tank or container storage area.

If, based on the visual inspection and the on-site screening analyses, the spent carbon is different than that described on the customer Spent Carbon Profile Form and/or the

Spent Carbon:
 Profile Analytical Completed Off-Site Prior to Profile Approval:
 Visual Inspection
 Flash Point
 pH
 Compatibility
 Cyanide
 Sulfide
 Mercury
 Halogen Content

Spent Carbon
 As, Be, Cd, Cr, Pb, Hg, Cl
 Frequency - 4 / day to 1 / month Composite

Spent Carbon
 On-site Testing
 Flash Point, pH, Compatibility

Other Wastes Generated:

- Misc. Debris - Weekly - All Waste Codes Facility has received. Not Currently Tested Put in 90 day bin for incineration
- WWTP Filter Press Cake - All Waste Codes Facility has received. Not Currently Tested Put in 90 day bin for incineration

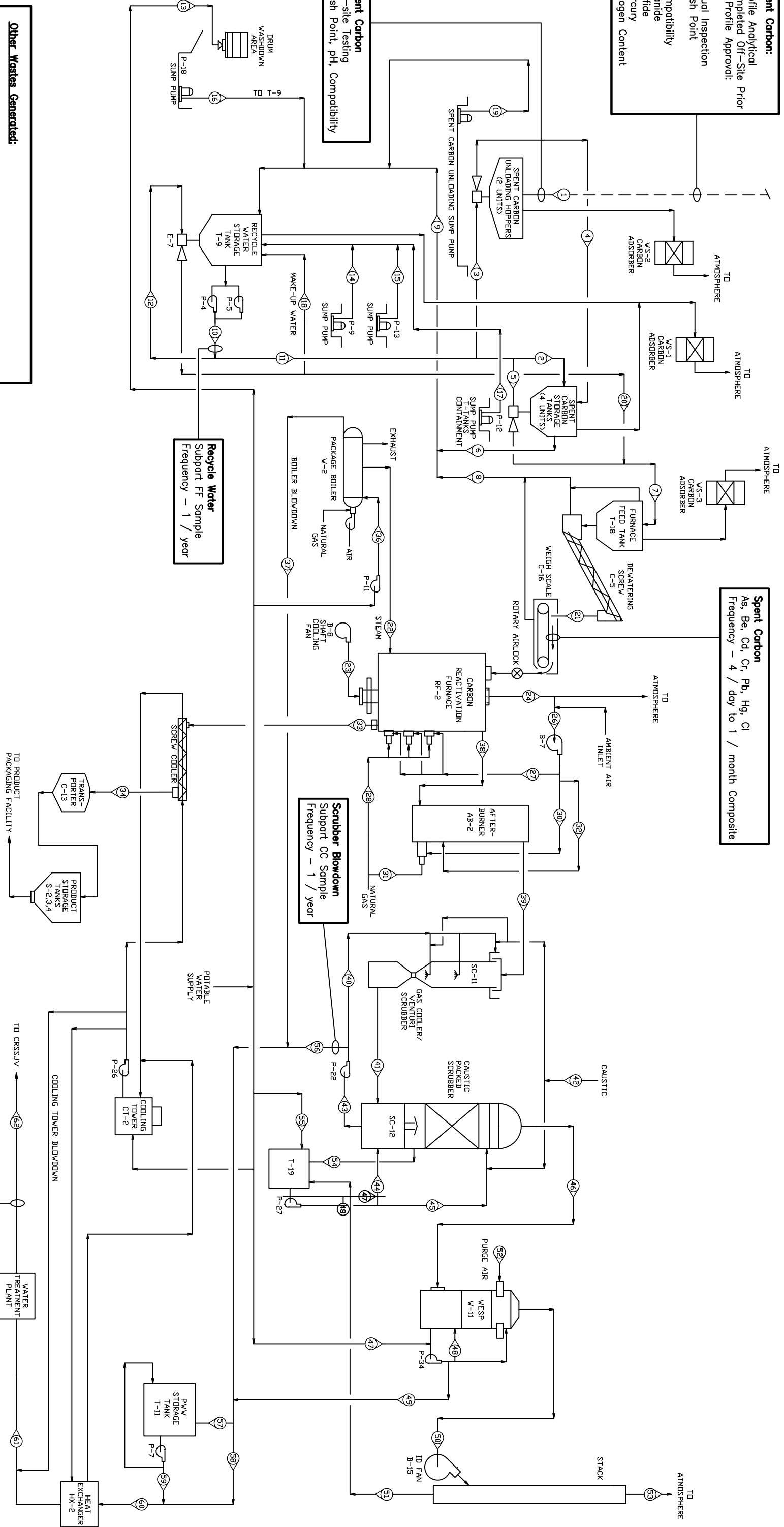

Scrubber Blowdown
 Subpart CC Sample
 Frequency - 1 / Year

Recycle Water
 Subpart FF Sample
 Frequency - 1 / Year

NOTES:
 1. THIS DRAWING INCLUDES COMPONENTS OF THE FACILITY THAT ARE EXCEPT FROM PERMITTING UNDER VARIOUS PROVISIONS OF RCRA. DATA RELATED TO THESE COMPONENTS IS PROVIDED FOR INFORMATIONAL PURPOSES AND EASE OF REVIEW ONLY, AND THEY ARE NOT INTENDED TO BECOME REGULATED COMPONENTS OF THE HAZARDOUS WASTE FACILITY.

Wastewater Discharge
 POTW COD/TSS Sample
 Frequency - 2 / month

Wastewater Discharge
 CWT Sample
 Frequency - 2 / year

Wastewater Discharge
 POTW TTO Sample
 Frequency - 1 / year

NO. 400		REV. 0	
DATE	DATE	DATE	DATE
7/6/11	7/7/11		
DRAWN: JBE		CHECKED: KEM	
DATE: 7/6/11		DATE: 7/7/11	
SCALE: NONE		DWG. NO.: WAP-001	
REV. 0		DATE: 7/7/11	

NO.	DATE	BY	REVISIONS
1	7/6/11	JBE	ISSUED FOR PERMITTING

SAMPLE LOCATIONS	
SIEMENS INDUSTRY, INC.	
2523 MITAHAR STREET, PARKER, AZ 85344	

Hazardous Waste Manifest, the generator will be notified of the discrepancy. If the discrepancy cannot be immediately resolved, the spent carbon may be retained on-site while the investigation of the discrepancy continues. If the discrepancy cannot be resolved, the spent carbon will be rejected and directed back to the generator or an alternate facility per generator direction. If the discrepancy cannot be resolved within 15 days, EWT will notify EPA as required by 40 CFR 264.72(b) and (c).

4.4 RATIONALE FOR ANALYSES SELECTED FOR ON-SITE SCREENING

The rationale for the analysis selected to be performed as part of the on-site screening is given in Table 4-2.

4.5 ANALYSES PERFORMED FOR PERMIT COMPLIANCE

The RF-2 carbon reactivation furnace conducted a Performance Demonstration Test and established feed rate limits for the following constituents as a result of that test:

- Mercury
- Semi volatile metals (cadmium, lead)
- Low volatility metals (arsenic, beryllium, chromium)
- Total chlorine/chloride.

In order to continuously demonstrate compliance with those feed rate limits, the most recent analytical results (designated as the “analysis of record”) are recorded in the process computer system. A rolling average feed rate of each regulated constituent is computed and recorded based on the analysis of record and the measured mass feed rate of spent activated carbon.

A grab sample of the feed spent activated carbon is collected four times daily (twice each shift) when the process is operating. These samples are collected by the process operators from the weigh belt. The four daily grab samples are stored in the on-site laboratory. At the end of each approximately 15 to 20 day period (selected such that the samples will not exceed the 28 day holding time for Hg analysis), the samples collected from that time period are combined and then sub-sampled to form a composite feed sample. This composite is analyzed using the methods described in Table 4-3.

Following receipt of the feed composite sample analyses, the data are entered into a spreadsheet where the most recent 12 months of analytical results are averaged. When each new analytical result is entered, the 12 month average is updated. The most recent 12 month average result is designated as the “analysis of record” for purposes of calculating the constituent feed rate values used for permit compliance demonstration.

While EWT’s contract laboratory matrix spike recovery results are routinely within the method limits, EPA has expressed concern that analyte recovery may be problematic in activated carbon samples. EWT has agreed to review the results of matrix spike

recoveries for the regulatory compliance analyses (metals and total chlorine) and to adjust the analytical result using the spike recovery if the recovery falls below the method limits. The following equation will be used if such analytical result adjustment is needed:

$$C_{corr} = C_{unc} \times \frac{100}{\text{Spike Recovery \%}}$$

Where:

C_{corr} = Corrected analytical result

C_{unc} = Uncorrected analytical result

TABLE 4-1
SUMMARY OF PRE-ACCEPTANCE ANALYTICAL PARAMETERS, RATIONALE, AND TEST METHODS

PARAMETER	RATIONALE	METHODS	USES
Visual Inspection	Verify that the material is spent carbon, and used to identify the obvious presence or absence of free liquid and/or debris, coloration, and whether the spent carbon is a vapor phase or liquid phase carbon, etc. The initial characterization of a particular spent carbon will be used for comparison against each subsequent load of that same spent carbon received at the facility.	Visual Inspection	Pre-acceptance
Flash-point (1)	Indicates whether the free liquid or solid portion of the spent carbon exhibits the characteristics of ignitability. This information is used to determine the storage requirements for the spent carbon prior to treatment. Liquids with a flash point <140°F will not be accepted into the facility.	SW-846 Method 1010M, 1010, or ASTM D3278	Pre-acceptance
pH (2)	Identifies materials that have the potential to corrode pipes, tanks and ancillary equipment.	SW-846 Method 9041, 9040, or 9045 depending on free moisture in sample	Pre-acceptance
Compatibility	Identifies materials that have the potential to be incompatible.	ASTM D5058 (Method C) or IM-101S	Pre-acceptance
Cyanide	Identifies potentially reactive spent carbon. Spent carbon with reactive cyanide >250ppm will not be accepted at the facility.	SW-846 Method 9010	Pre-acceptance
Sulfide	Identifies potentially reactive spent carbon. Spent carbon with reactive sulfide >500ppm will not be accepted at the facility.	SW-846 Method 9030	Pre-acceptance
Mercury	Process information.	SW-846 Method 7471 (Cold Vapor Technique)	Pre-acceptance
Halogen Content	Process information.	SW-846 Method 5050 (bomb combustion) SW-846 Method 9020 or 9056	Pre-acceptance

Notes:

1. If fingerprinting with an open flame is positive then run one of the methods.
2. Analysis performed on free liquids retained in incoming spent carbon samples or on a 1:1 mixture of the incoming vapor phase carbon sample and deionized water. Initial screening is performed using Method 9041. Should Method 9041 indicate the sample is potentially corrosive, Method 9040 or Method 9045 is used for final confirmation that a material is corrosive.
3. All method numbers are shown without suffix. The latest promulgated method will be used.
4. SW-846 refers to *Test Methods for Evaluating Solid Waste, Physical/Chemical Methods*, USEPA, latest update. ASTM refers to *Annual Book of ASTM Standards*, ASTM International.

Table 4-2
SUMMARY OF ON-SITE SCREENING ANALYTICAL PARAMETERS, RATIONALE AND TEST METHODS

PARAMETER	RATIONALE	METHODS	USES
Visual Inspection	Verify that the material is spent carbon, and used to identify the obvious presence or absence of free liquid and/or debris, coloration, and whether the spent carbon is a vapor phase or liquid phase carbon.	Visual	On-site screening; Must conform to physical description on profile
Ignitability(1)	Indicates whether the carbon will support a flame at ambient conditions. This information is used to determine the storage requirements for the spent carbon prior to treatment, and to verify ignitability information provided by the generator.	Open ignition in controlled environment	On-site screening; Diluted sample must not support combustion
pH	Identifies materials that have the potential to corrode pipes, tanks and ancillary equipment.	Add DI water 1:1 and check pH using test strips. (Reference: EPA Method 9041M/9045M)	On-site screening; Must be within range on profile
Compatibility	Identifies materials that have the potential to be incompatible with water.	ASTM D5058 (Test Method C – Water Compatibility) or IM-101S	On-site screening; Must not show adverse reaction with water

Notes:

(1) Fingerprinting is conducted by applying a flame to the carbon sample in a controlled environment. If the carbon supports a flame under these conditions, the sample is mixed 1:1 with deionized water and the procedure is repeated. The test is positive if the diluted sample supports combustion above the water surface.

Method numbers are shown without suffix. The latest promulgated methods will be used.

SW-846 refers to *Test Methods for Evaluating Solid Waste, Physical/Chemical Methods*, USEPA, latest update.
ASTM refers to *Annual Book of ASTM Standards*, ASTM International.

TABLE 4-3
SUMMARY OF PERMIT COMPLIANCE ANALYTICAL PARAMETERS, RATIONALE, AND TEST METHODS

PARAMETER	RATIONALE & FREQUENCY	METHODS	USES
Arsenic, Beryllium, Cadmium, Chromium, Lead	Demonstrate compliance with RF-2 constituent feed rate limits. Four daily samples combined and sub-sampled into ~15 to 20 day composite. Analysis of each composite to form 12-month rolling average.	SW-846 Method 3050 (acid digestion) SW-846 Method 6010 (ICP)	Calculation of constituent feed rate; comparison to permit limit.
Mercury	Demonstrate compliance with RF-2 constituent feed rate limits. Four daily samples combined and sub-sampled into ~15 to 20 day composite. Analysis of each composite to form 12-month rolling average.	SW-846 Method 3050 (acid digestion) SW-846 Method 7471 (CVAAS)	Calculation of constituent feed rate; comparison to permit limit.
Total chlorine	Demonstrate compliance with RF-2 constituent feed rate limits. Four daily samples combined and sub-sampled into ~15 to 20 day composite. Analysis of each composite to form 12-month rolling average.	SW-846 Method 5050 (bomb combustion) SW-846 Method 9056	Calculation of constituent feed rate; comparison to permit limit.

Note: method numbers are shown without suffix. The latest promulgated methods will be used.

SW-846 refers to *Test Methods for Evaluating Solid Waste, Physical/Chemical Methods*, USEPA, latest update.

5.0 PROCEDURES USED TO OBTAIN A REPRESENTATIVE SAMPLE OF SPENT CARBON

Sampling of spent carbon will be employed as part of the on-site screening process and permit compliance as described below.

5.1 BULK LOADS

A representative sample of each bulk load will be obtained using either a shovel or scoop. The sampling instrument will be rinsed with water after every sampling event. The sample from each bulk shipment will be taken to the laboratory for screening analyses.

5.2 CONTAINERS

Each container will be opened for the purpose of inspection and sampling. The lid or top on each container will be left loosely in place unless sampling or inspection of the container is actually occurring. A Material Handler or another designated employee will obtain one sample from each randomly selected container using the following selection strategy.

1. The number of containers chosen for random selection from each spent carbon generator will equal the square root plus one of the total shipped by the generator in each load. Thus, if a generator shipped one container, that container would be sampled. If a generator shipped sixteen containers, five would be sampled. If the square root is not an integer, it will be rounded to the next highest number. The waste tally sheet and EWT internal labels are generated by computer and perform the random sampling calculations. Printed tally sheets and labels designate which containers are to be sampled.
2. If any container contains a spent carbon which either is visually different from the profiled spent carbon, or a composite of the individual samples fails the on-site screening process described in Section 4, each container from that spent carbon generator may be sampled and subjected to the on-site screening analyses listed in Table 4-2.

Each representative sample will be obtained using the appropriate adaptation of the general methodology listed in ASTM Standard D346. The sample will be placed in clean sample jars, covered with an appropriate lid, and immediately taken to the facility laboratory for analysis. A label will be placed on each jar, indicating the profile number and the date of the sample. After sampling, the lid will be replaced on each container and it will be sealed if it is going to be stored. A composite sample will be analyzed from each load of spent carbon received from each generator. The composite sample will be prepared by combining equal amounts of carbon from each grab sample that was collected from the randomly selected containers in the load.

5.3 CARBON FEED

Four times daily, the access cover of the weigh belt will be opened for the purpose of sampling. An operator or another designated employee will obtain one grab sample of the feed carbon, and place the sample into a clean sample jar.

At the end of each day, the four grab samples will be stored in the on-site laboratory.

At the end of each approximately 15 to 20 day period, the daily feed samples will be opened and an equal amount will be removed from each jar and placed into a clean sample jar, to form a carbon feed composite sample.

A label will be placed on the composite sample jar, indicating the date range of the sample, and the sample will be sent to an off-site laboratory for the analyses listed in Table 4-3.

5.4 MAINTAINING AND DECONTAMINATING SAMPLING EQUIPMENT

Equipment used to obtain representative samples will be inspected as per the facility's inspection schedule to ensure it is in proper working order. Sampling equipment will be decontaminated by rinsing with water after each sampling event.

5.5 SAMPLING QA/QC PROCEDURES

Sampling equipment is decontaminated between sampling events or is disposed of to minimize the possibility of cross contamination. The equipment is decontaminated using a method appropriate to the type of material sampled. For example, scoops are generally rinsed with water to remove solids. New sampling equipment that is known to be clean will not be decontaminated prior to use.

6.0 METHODS TO ENSURE COMPATIBILITY WITH HANDLING METHODS

The spent carbon testing procedures outlined in this Waste Analysis Plan have been developed with cognizance of the spent carbon storage and handling procedures at the Parker facility. The facility is designed to safely store, transfer and reactivate spent carbon, which is contaminated with wastes that are toxic and/or ignitable. The Parker facility takes the necessary precautions to prevent the accidental ignition of ignitable spent carbon. As shown in Table 4-1, the facility pre-acceptance procedures include compatibility testing to identify materials that have the potential to be incompatible. The facility will not receive spent carbon which is characterized by the generator as reactive or corrosive, or spent carbon identified by waste codes which are not authorized for receipt at the facility.

7.0 METHODS TO ENSURE WASTE ANALYSIS PLAN IS KEPT UP-TO-DATE

The Plant Manager, Environmental Health and Safety Specialist or another designated person shall review the Waste Analysis Plan at least every two calendar years to determine if it is in compliance with current RCRA regulations and otherwise meets the needs of the facility. A statement that the plan was reviewed will be maintained in the permanent files at the facility.

If the WAP is revised as a result of the review process, a copy of the revised document will be provided to EPA.

8.0 LAND DISPOSAL RESTRICTION NOTIFICATION FORMS

Generators of spent carbon that is restricted from land disposal pursuant to 40 CFR 268 will be required to provide appropriate documentation.

At the time of spent carbon receipt, EWT will receive and review the forms, which must accompany the first shipment of spent carbon that is subject to land ban restrictions. EWT will file the completed forms with the Treatment Storage and Disposal copy of the hazardous waste manifest as part of the facility operating record.

9.0 SPECIAL PROCEDURAL REQUIREMENTS

This section provides discussion on special procedural requirements applicable to the facility. These include 40 CFR 264 Subpart BB and Subpart CC applicability.

9.1 Subpart BB

In accordance with the requirements of 40 CFR 264 Subpart BB, the Waste Analysis Plan is to contain determinations on the applicability of the 40 CFR 264 Subpart BB requirements. The Subpart BB regulations are applicable to equipment that contains or contacts hazardous wastes with organic concentrations of at least ten (10) percent by weight.

The Subpart BB regulations further define equipment as being in light liquid service, gas/vapor service, and heavy liquid service. The facility Subpart BB Compliance Plan is included in Appendix XIX of the Part B Application.

9.2 Subpart CC

The EWT Parker facility manages all tanks and containers regulated by the requirements of Subpart CC as specified in Section O. The Subpart CC Compliance Plan is located in Appendix XVI. The carbon absorber change out schedules are based on engineering calculations found in 40 CFR, Subpart FF Compliance Plan.

9.3 Wastes Generated On-Site

EWT generates several regulated waste streams as part of its operations. These include debris, filter cake from the wastewater treatment operations, used personnel protective equipment, and spent activated carbon used for tank vent control in compliance with Subpart CC and FF. Of these wastes, all are manifested and sent off site for disposal, with the exception of the spent activated carbon used for tank vent control. This spent activated carbon is similar to the spent carbon received at the EWT facility, as it is derived from the treatment and storage of those carbon streams, and is treated by EWT in the same manner as the spent carbon received from off-site.

WASTE ANALYSIS PLAN

APPENDIX A

WASTE PROFILE FORMS

Revision 2
March 2016

PROFILE INSTRUCTIONS

1. **Generator information** The generator of the spent carbon must provide all requested contact information. Completely fill in the mailing address of the generator of the spent carbon. The mailing address is where the manifest will be mailed and must match the manifest mailing address. Completely fill in the name of person responsible for completing the Profile Form and who can be contacted with questions concerning the Profile Form and/or shipment(s). The Site EPA Identification Number must be included if the spent carbon is hazardous.

2. **Consultant information** If a consultant or subcontractor is providing the profile information on behalf of the generator, the consultant information must be filled out entirely. Completely fill in the street address of the site location of the spent carbon if it is different from 1(a). The address must match the information for the EPA ID Number. If generator, site and/or consultant are the same, please indicate "same". If none, please state "none or n/a".

3. **Properties and Composition of the Spent Carbon** In addition to a specific description of the process generating the spent carbon enter the specific constituents on the carbon. Please be specific when entering the data in this field, see the examples below.

Example of unacceptable description of constituents: VOC's from soil vapor extraction, halogenated hydrocarbons, and other VOC's, etc.

Example of acceptable description of constituents: Groundwater remediation to remove benzene or BTEX from a LUST, groundwater remediation for tetrachloroethylene in the vicinity of a dry cleaner, etc. Please list the source of the contamination if known.

4. **Existing Profile Number** If there is an existing profile number for the spent carbon include the previous approved profile number and expiration date in this section.

5. **Type of Spent Carbon** Select the applicable carbon type vapor or aqua phased.

6. **Foreign Material** If the carbon contains any foreign materials such as dirt, rocks or other foreign materials, a representative sample must be sent to the Parker facility at the Arizona physical address for evaluation. A one pound sample is adequate. If nothing is present, please check off "no."

7. **Handling** Indicate the container in which the carbon will be shipped. Note: containers containing hazardous materials must meet general packaging requirements DOT 49 CFR 173.24. (a)(b).

8. **Free Liquid Range** An estimated range of free liquid accompanying the spent carbon must be selected.

9. **Liquid Flashpoint** If the flashpoint range of the free liquid has not yet been determined, please send a sample to SWT for analysis.

10. **pH Range** If the pH has not yet been determined, please send a sample to the SWT for analysis.

11. **Strong Odor** If the carbon contains a strong odor a sample must be sent to the Parker facility at the Arizona physical address for evaluation. A one pound sample is adequate.

12. **Superfund Site** If the spent carbon is from a Superfund site please check the "yes" box. A Superfund site is identified by the Comprehensive Environmental Response, Compensation and Liability Act of 1980, or the Superfund Amendments and Reauthorization Act of 1986 (SARA).

13. **Benzene NESHAP** If the spent carbon comes from a process meeting the requirements of 40 CFR 61.341, please check the "yes" box. The BWON Addendum must be completed and attached to the Profile Form. Total benzene analysis is required on BWON waste streams.

14. **Carbon Containing the Following** If the spent carbon contains any contaminants listed in items A-I on the Profile Form please check the appropriate box "yes".

- A. If the spent carbon contains PCBs the Addendum for Non-Regulated PCB Waste must be completed and attached to the Profile Form. Please note the required analysis for each shipment.
- B. Dioxins and/or furans will not be accepted at either the Parker or Red Bluff facility.
- C. If the spent carbon contains DBCP additional analysis and a review will be required before the profile can be approved.
- D. Sulfide or Cyanide will not be accepted at either the Parker or Red Bluff facility.
- E. Explosives, pyrophoric or radioactive material will not be accepted at either the Parker or Red Bluff facility.
- F. Infectious materials will not be accepted at either the Parker or Red Bluff facility.
- G. Shock sensitive material will not be accepted at either the Parker or Red Bluff facility.
- H. Oxidizers will not be accepted at either the Parker or Red Bluff facility.
- I. Heavy metals must be identified and totals, not TCLP, metals analysis must be conducted and attached to the Profile Form.

15. **Generator Classification** Indicate if the spent carbon is considered a hazardous waste under federal RCRA regulations. List all applicable waste codes. (Please see 40 CFR Part 261.31- 261.33 for listed waste codes and 40 CFR Part 261.21 – 261.24 for characteristic waste codes). The federal EPA and many states provide that a spent carbon may be classified as "sludge" when generated from an air pollution control facility municipal, commercial, or industrial wastewater treatment plant or a water supply treatment plant and the spent carbon contains no listed hazardous waste. To qualify for this exemption, the spent carbon must be returned to a reactivation facility where the spent carbon is reclaimed and the spent carbon must be generated in a state whose regulations provide for the classification of such spent carbon as a "sludge." If the spent carbon meets the requirements of 40 CFR 261.2(c)(3) and the state where it is generated, an Addendum for Sludge Exemption must be completed and submitted with the Profile Form. Note: It is the generator's responsibility to classify the spent carbon.

16. **Generator Classification** Indicate if the spent carbon is considered a hazardous waste under regulations of the state in which it is generated. If so, list all applicable state waste codes. Note: It is the generator's responsibility to classify the spent carbon.

17. **Land disposal restriction notification** The USEPA Hazardous Waste Land Disposal Restrictions require that every generator of restricted hazardous waste send a notification that describes the waste and its status under the Land Ban regulations. 40 CFR 268.

18. **Estimated annual carbon usage** Indicate an estimate of the annual carbon usage, in pounds per year, for the specific profile.

ANALYTICAL REQUIREMENTS

Analytical data on the spent carbon are required with each new Profile Form and with each renewal Profile Form even if the waste stream has not changed. Spent carbon should be analyzed for the constituents being treated in the waste stream. Analysis must have been performed within the last six (6) months by a state-certified laboratory, such as the Evoqua Water Technologies laboratory.

RCRA Profiles only

RCRA hazardous profiles require additional testing; "11 RCRA Tests". A one-pint sample of the spent carbon must be submitted to Evoqua Water Technologies, Attn: Lab, 5375 S. Boyle Ave., Los Angeles, CA 90058. It is recommended the "11 RCRA Tests" be performed at by the EWT lab in Vernon, CA because internal test methods are required. A completed and signed LDR is required to be submitted prior to profile approval.

PROFILE APPROVAL

Submit the completed electronic Profile Form and all required Addenda via email to your Evoqua Sales representative along with spent carbon samples for testing. Notification of approval will be forwarded to the consultant (if listed) or the generator via email. Upon receipt of your profile approval letter, contact your EWT Sales Representative to schedule service and transportation.

Evoqua Water Technologies LLC

Arizona Facility: 2523 Mutahar Street • P.O. Box 3308 • Parker, AZ 85344

(928) 669-5758 • FAX (928) 669-5775 EPA ID: AZD 982 441 263

California Facility: 11711 Reading Road • Red Bluff, CA 96080

(530) 527-2664 • FAX (530) 527-0544 EPA ID: CAR 000 058 784

SPENT CARBON PROFILE FORM

GENERATOR INFORMATION

1. a) Generator: _____
Mailing Address: _____
(Manifest Return) _____
- b) Site: _____
Address: _____

- c) Contact Name: _____
- e) Phone No: _____
- d) EPA ID#: _____
- f) Fax No: _____

CONSULTANT INFORMATION

2. a) Consultant: _____
Mailing Address: _____

- b) Contact: _____
- c) Phone: _____
- d) Fax: _____
- e) Email: _____

PROPERTIES AND COMPOSITION OF THE SPENT CARBON

3. Provide a specific description of the process generating the spent carbon including constituents being treated.
(Please note if application is for potable water or food processing)

4. If this is a Renewal, Provide the Existing Profile Approval Number: _____
5. Type of Spent Carbon: Aqueous Vapor
6. Foreign Material: Yes No (rocks, dirt, sand, etc.)
7. Handling: Bulk Drum Adsorber Bulk Bag Other _____
8. Free Liquid Range: 0 1 – 15%
9. Liquid Flashpoint: < 140°F >140°F N/A Vapor
10. pH Range: <2 2-4 4.1-10.5 >10.5
11. Strong Odor? Yes No If yes, please Describe _____
12. Is spent carbon generated from a Superfund Site? Yes No

13. Is the Spent Carbon generated from any activity at a chemical manufacturing plant, petroleum refinery or coke by-product recovery plant, i.e., a facility subject to Subpart FF (the Benzene Waste NESHAP)? Yes No
If yes, complete BWON Addendum.
14. Is the Spent Carbon generated from any activity at an ethylene manufacturing process unit subject to 40 CFR Part 63, Subpart XX (Ethylene MACT)? Yes No
If yes, complete the Ethylene MACT Addendum
15. Does the spent carbon contain any of the following?
- A. Polychlorinated Biphenyls (PCBs) Yes No
 - B. Dioxins and/or Furans Yes No
 - C. Dibromochloropropane (DBCP) Yes No
 - D. Sulfide or Cyanide Yes No
 - E. Explosive, Pyrophoric and/or Radioactive material Yes No
 - F. Infectious material Yes No
 - G. Shock Sensitive material Yes No
 - H. Oxidizer Yes No
 - I. Heavy Metals Yes No

GENERATOR CLASSIFICATION

16. Is the Spent Carbon a **RCRA** Hazardous Waste? Yes No
 If yes, list waste code(s) below:
RCRA Hazardous Waste requires "11 RCRA" Analysis

17. Is the Spent Carbon a **State** Hazardous Waste? Yes No
 If yes, list waste code(s) below:

GENERATOR CERTIFICATION

I hereby certify that all information on this and all attached documents are true and that this information accurately describes the subject spent carbon. I further certify that all samples and analyses submitted are representative of the subject spent carbon in accordance with the procedures established in 40 CFR 261 Appendix I or by using an equivalent method. All relevant information regarding known or suspected hazards in the possession of the generator has been disclosed. I authorize Evoqua Water Technologies LLC to obtain a sample from any waste shipment for purposes of confirmation or further investigation. If I am a consultant signing on behalf of the generator, I have their proper approval.

Printed Name

Signature

Title

Date

NOTE: A completed and signed LDR must be submitted prior to profile approval for RCRA-regulated spent carbon.

For Internal Use Only

 Profile Approval Number

 Valid Through

Evoqua Water Technologies LLC

Arizona Facility: 2523 Mutahar Street • P.O. Box 3308 • Parker, AZ 85344

(928) 669-5758 • FAX (928) 669-5775

EPA ID: AZD 982 441 263

PROFILE ADDENDUM FOR SLUDGE EXEMPTION

Generator: _____

Site Address: _____ **City/State:** _____

The following information must be provided before approval of the profile if the generator requests that the spent carbon be classified as a non-hazardous sludge for reclamation in accordance with 40 CFR 261.2.

1. Is the subject spent carbon a sludge, as defined at 40 CFR 260.10?
Yes No
2. Was the subject spent carbon generated from a municipal, commercial, or industrial wastewater treatment plant or water supply treatment plant or air pollution control facility?
Yes No
3. Is the subject spent carbon a RCRA listed waste?
Yes No
4. Was the subject spent carbon ever placed in contact with, or used to treat, a RCRA **listed** waste?
Yes No
5. Was the subject spent carbon generated by a RCRA regulated treatment, storage or disposal facility?
Yes No
6. If question 5 is checked YES, does it "contain" or is it "derived from" a RCRA listed waste?
Yes No
7. Is the subject spent carbon exempt from hazardous waste regulation in the state of generation?
Yes No

I certify that the information on this form is true and accurately describes the subject spent carbon on the attached spent carbon profile form. I further certify that the subject spent carbon is exempt from regulation as a hazardous waste.

Printed Name

Signature

Title

Date

Evoqua Water Technologies LLC

Arizona Facility: 2523 Mutahar Street • P.O. Box 3308 • Parker, AZ 85344

(928) 669-5758 • FAX (928) 669-5775

EPA ID: AZD 982 441 263

California Facility: 11711 Reading Road • Red Bluff, CA 96080

(530) 527-2664 • FAX (530) 527-0544

EPA ID: CAR 000 058 784

PROFILE ADDENDUM LISTED WASTE APPLICABILITY

Generator: _____

Site Address: _____ **City/State:** _____

1. Does the spent carbon contain constituents from a pure product release or tank vent?
 Yes **No** **Unknown ****

2. Is the spent carbon from a cleanup of PCE, TCE or other spent solvents from a dry cleaner or from degreasing or other cleaning operations?
 Yes **No** **Unknown ****

3. Is the original process generating the waste an F, K, P or U-listed process?
 Yes **No** **Unknown ****

** Check the "Unknown" box if this material is generated from remediation activities and the historical processes have not been determined.

I certify that the information on this form is true and accurately describes the subject spent carbon on the attached spent carbon profile form.

Printed Name

Signature

Title

Date

Evoqua Water Technologies LLC

Arizona Facility: 2523 Mutahar Street • P.O. Box 3308 • Parker, AZ 85344
 (928) 669-5758 • FAX (928) 669-5775 EPA ID: AZD 982 441 263

PROFILE ADDENDUM FOR BENZENE WASTE OPERATIONS NESHAP (BWON) 40 CFR PART 61, SUBPART FF

Generator: _____

Site Address: _____ **City/State:** _____

1. Is the Spent Carbon generated from any activity at a chemical manufacturing plant, petroleum refinery or coke by-product recovery plant, i.e., a facility subject to Subpart FF (the Benzene Waste NESHAP)?

Yes No

2. If Yes, does the spent carbon contain any benzene?

Yes No

If Yes, the Generator must provide analytical data for total benzene concentration that is representative of the waste stream, consistent with 40 CFR § 61.355.

3. If Yes, does the Spent Carbon contain benzene which is required to be managed and treated in accordance with the provisions of Subpart FF?

Yes No

If Yes, the Generator agrees that it will:

- (i) send a notice with each shipment of Spent Carbon that is subject to Subpart FF stating that the shipment contains benzene and must be managed and treated in accordance with Subpart FF [40 CFR § 61.342(f)(2)]; and
- (ii) Prior to each shipment, test each container of Spent Carbon subject to Subpart FF test requirements to confirm no detectable emissions using EPA Method 21 upon initial use of the container [40CFR § 61.345(a)(1)(i)].

In addition to certification on the attached Spent Carbon Profile Form, I further certify that all information on this Addendum is true and accurate, and that all samples and analyses submitted are representative of the subject spent carbon in accordance with the procedures established in 40 CFR § 61.355.

Printed Name

Signature

Title

Date

Evoqua Water Technologies LLC

Arizona Facility: 2523 Mutahar Street • P.O. Box 3308 • Parker, AZ 85344

(928) 669-5758 • FAX (928) 669-5775

EPA ID: AZD 982 441 263

California Facility: 11711 Reading Road • Red Bluff, CA 96080

(530) 527-2664 • FAX (530) 527-0544

EPA ID: CAR 000 058 784

PROFILE ADDENDUM FOR NON-REGULATED PCB WASTE

Generator: _____

Site Address: _____ **City/State:** _____

1. Does the subject spent carbon contain < 50 ppm PCBs?
 Yes No
2. Does the influent from the subject spent carbon contain < 50 ppm PCBs?
 Yes No
3. Is the subject spent carbon regulated under 40 CFR Part 761?
 Yes No

I certify that the information on this form is true and accurately describes the subject spent carbon on the attached spent carbon profile form. I further certify that any PCBs (Polychlorinated Biphenyls) on the carbon is non-regulated under 40 CFR Part 761 (non TSCA regulated). I will submit PCB analytical results of the carbon prior to each shipment.

Printed Name

Signature

Title

Date

Evoqua Water Technologies LLC

Arizona Facility: 2523 Mutahar Street • P.O. Box 3308 • Parker, AZ 85344

(928) 669-5758 • FAX (928) 669-5775

EPA ID: AZD 982 441 263

PROFILE ADDENDUM FOR ETHYLENE MANUFACTURING PROCESS UNIT WASTES MACT 40 CFR PART 63, SUBPART XX

Generator: _____

Site Address: _____ **City/State:** _____

1. Is the Spent Carbon generated from any activity at an ethylene manufacturing process unit subject to 40 CFR Part 63, Subpart XX (the Ethylene MACT)?

Yes **No**
2. If Yes to Q. 1, does the spent carbon contain any benzene which is required to be managed and treated in accordance with the provisions of the Ethylene MACT?

Yes **No**
3. A. If Yes to Q. 1, does the spent carbon contain any 1,3-butadiene which is required to be managed and treated in accordance with the provisions of the Ethylene MACT?

Yes **No**

B. For carbon that contains any 1,3-butadiene, was the carbon used to manage and/or treat a continuous butadiene waste stream that contained greater than or equal to 10 ppmw 1,3-butadiene and with a flow rate greater than or equal to 0.02 liters/minute?

Yes **No**

If Yes, the Generator agrees that it will:

- (i) send a notice with each shipment of spent carbon that is subject to the Ethylene MACT stating that the shipment contains organic HAPs that are required to be treated in accordance with the Ethylene MACT, 40 CFR Part 63, Subpart XX; and
- (ii) Prior to each shipment, test each container of spent carbon subject to the Ethylene MACT test requirements to confirm no detectable emissions using EPA Method 21 upon initial use of the container [40CFR § 61.345(a)(1)(i)].

In addition to certification on the attached Spent Carbon Profile Form, I further certify that all information on this Addendum is true and accurate, and that all samples and analyses submitted are representative of the subject spent carbon in accordance with the procedures established in 40 CFR §§ 63.1095 and 61.355.

Printed Name

Signature

Title

Date

WASTE ANALYSIS PLAN

APPENDIX B

EXAMPLE SPENT CARBON TALLY SHEET

Revision 2
March 2016

Siemens Industry Inc.
**Incoming Spent Carbon Waste Tally and On-site
 Screening Report**

CC

Generator Name			Approval #
SAMPLE WASTE TALLY			W120000RH
Container Type	Quantity	Manifest #	Samples
Bag	5	123456	

On-site Screening Report

Results taken from containers were:

Ignitable Solid		Compatable		Composite PH (4.1 to 10.5)
Yes	No	Yes	No	
On-Site Screening Completed By (Sign Below)				Date

Container	% Full	* Sealed? (see note below)	Material	Sample
1				<input checked="" type="checkbox"/>
2				<input checked="" type="checkbox"/>
3				<input checked="" type="checkbox"/>
4				<input checked="" type="checkbox"/>
5				<input type="checkbox"/>

* For FF and CC Containers a check under Sealed, shall mean a visual inspection of the container has been completed and there are no visible cracks, holes, gaps or other open spaces into the interior of the container when the cover and closure device is secured in the closed position. If the inspection is unsatisfactory, the containers will either be overpacked or transferred to the spent carbon storage tank within the first 24 hours of receipt.

WASTE ANALYSIS PLAN

APPENDIX C

ON-SITE SCREENING PROCEDURES

Revision 2
March 2016

Siemens Industry, Inc.

Standard Methods for Screening Incoming Spent Carbon

Scope and Application

Siemens Industry, Inc. (SII) will screen all incoming RCRA hazardous spent carbon to assure that the parameters in the fingerprint tests corresponds to the approved profile.

Safety and Waste Handling

Procedures shall be carried out in a manner that protects the health and safety of all Siemens employees. When handling samples safety glasses and appropriate gloves must be worn. Gloves that have been contaminated will be removed and discarded. Exposure to chemicals must be maintained as low as reasonably achievable, therefore all samples must be opened and prepared in a fume hood. Waste containers will be kept closed unless transfers are being made.

Since the ignitability test requires the use of an open flame, keep the area clear of all other flammable materials.

All work must be stopped in the event of a known or potential compromise to the health and safety of Siemens employees.

Summary of Methods

Fingerprinting tests include; physical inspection, ignitability, pH and compatibility of RCRA hazardous incoming spent carbon.

Procedures

Physical Inspection

Samples are visually inspected for the presence of material other than carbon such as rocks, debris, etc. Technician will determine if the carbon is aqua phase or vapor phase and document findings on the waste tally sheet.

pH test

In a beaker add a volume of deionized water that is equal to that of the carbon. Stir and let it stand for five seconds. Measure the pH using pH test strips. The color change is compared to the chart on the box and the value is documented on the waste tally sheet for review by plant management. If the pH is <3 or > 11 , or outside the pH range of the profile notify your supervisor.

Compatibility Test

After taking the pH of the carbon sample let the mixture stand for one minute and observe for reaction such as smoke, vapors or for an exothermal reaction. Results of this test are documented on the waste tally sheet for review by plant management. If any reaction occurs notify your supervisor.

Ignitability test

Check the ignitability of carbon by using a multi-purpose lighter and applying a flame directly to the carbon for 5 seconds. If the carbon burns and continues to sustain a flame it may be considered ignitable. If this occurs, mix the sample 50/50 with deionized water and reapply a flame for 5 seconds. If the liquid sustains a flame, the carbon will be deemed ignitable. Results of this test are documented on the waste tally sheet for review by plant management.

Documentation and Record Keeping

Results are recorded on a waste tally sheet and signed by the technician performing the procedures. Plant management reviews results to determine if carbon is acceptable to be received into the plant. Samples are stored in the warehouse for (30) days.